

UNPLATING REEL	PLATING	PART NO.	DESCRIPTION		PIECE
A6600000A	A6660015A	A6660015A	UNDERPLATING	A Point B Point	1SPIN
			CU 20μ~30μ	AG 80μ	

REV	DESCRIPTION	BY	DATE
A	NEW DRAWING	J.S.SHEU	02/13/09
B	ECN 1007-005	JOE	07/06/10
C	ECN 1008-010	JOE	09/01/10
D	ECN 011-001	Ted	11/04/10

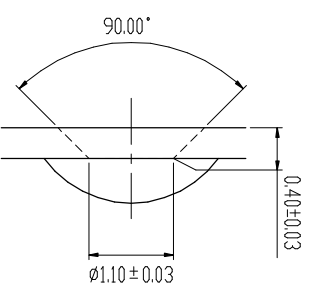

"C" S=10/1

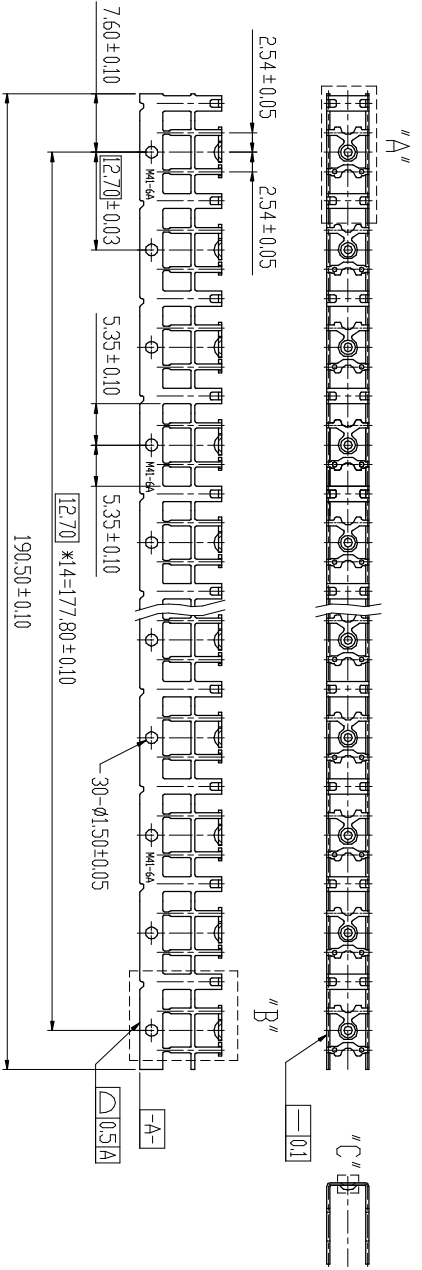
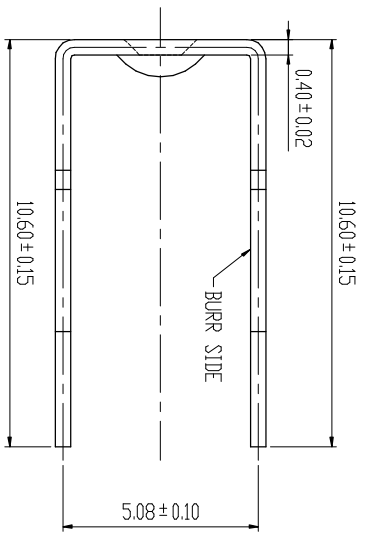
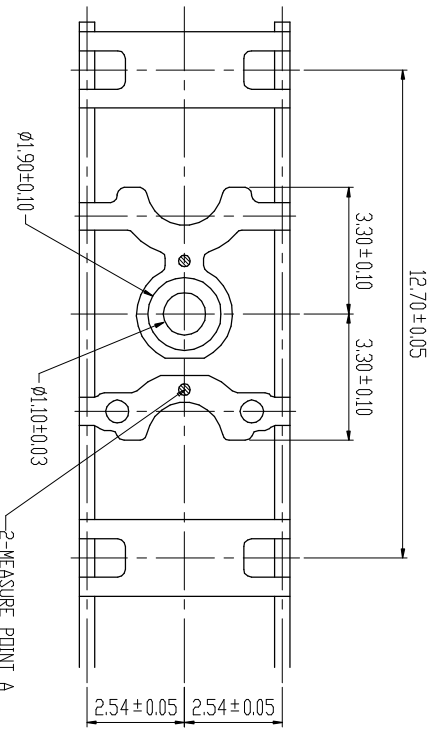

"B" S=5/1

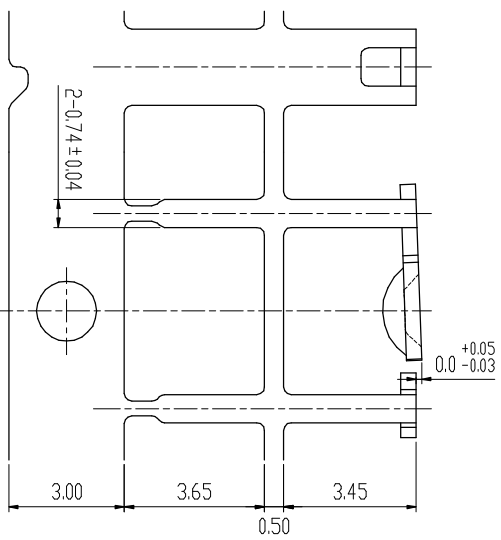

- NOTE:
1. MATERIAL: 0.40±0.02 THICK COPPER ALLOY-194 1/2H
  2. PLATING DF NINE MEASURING POINT FOR TABLE : AG 30μ MIN.
  3. RADIUS: 0.30 MAX. ON ALL SHARP CORNERS UNLESS OTHERWISE SPECIFIED.
  4. BURR: 0.03 MAX. UNLESS OTHERWISE SPECIFIED.
  5. CAN NOT BE DISCOLD AFTER BY 170° BAKING FOR 1.5 HOURS.

ANGLES 0°±20'	MM	DR	DATE	MAT'L
0.0±0.13	CHK	Ted	11/04/10'	SEE NOTE 1
0.00±0.05	ENGR	Ted	11/04/10'	FINISH SEE PART NO. TABLE
0.000±0.03	APPD			DWG. NO. M0346

CHALIN PRECISION INDUSTRIAL CO., LTD.			
DWG TYPE	TITLE	REV	
C	2041-M41-6AU	D	
SCALE	SIZE	PART NO.	
1:1	A4	E03046-A666XU15A	
		SHT 1 OF 2	