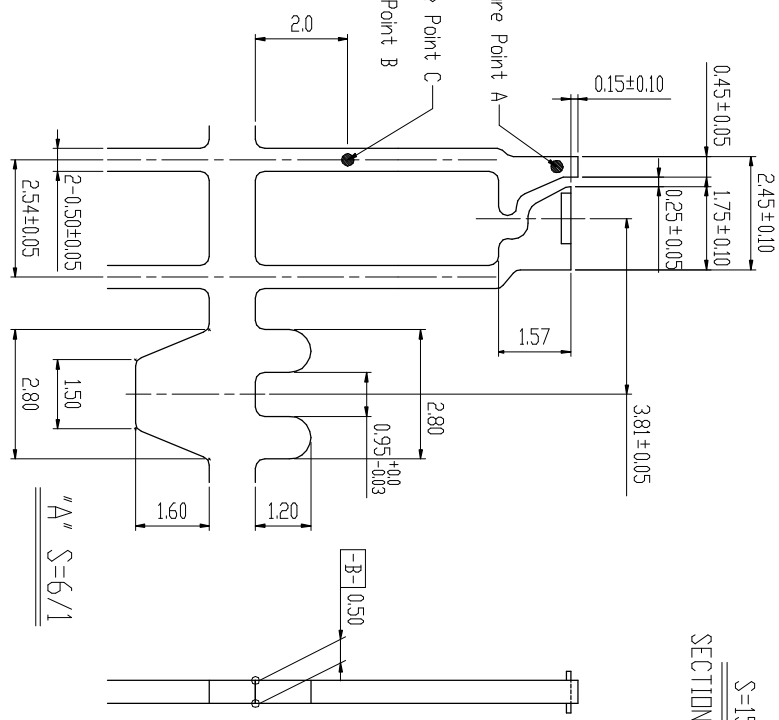
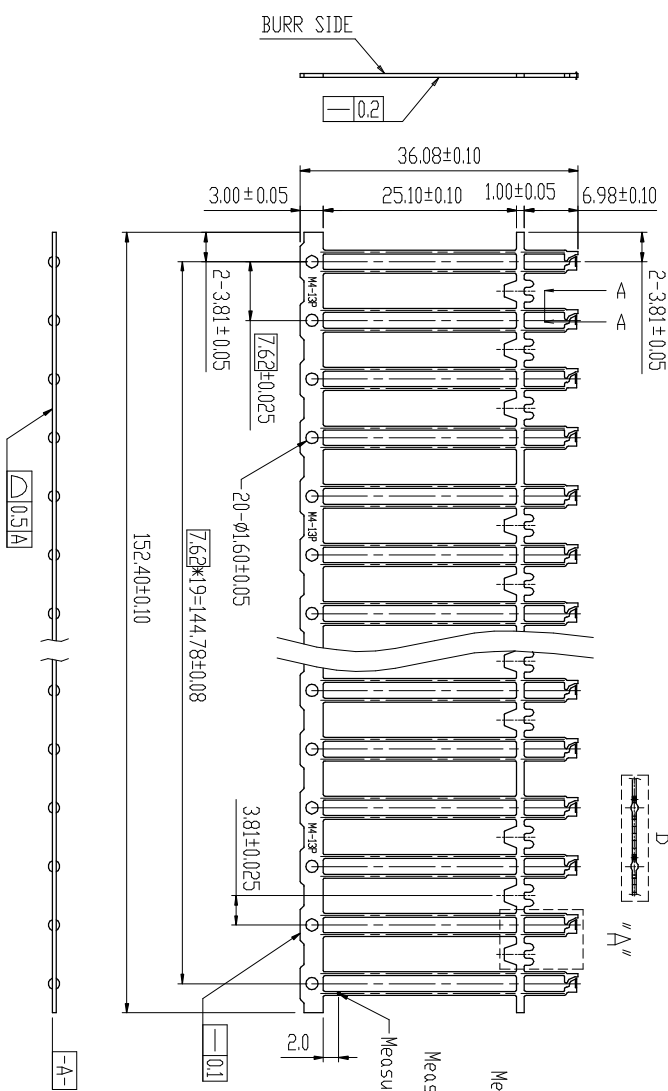
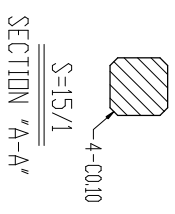
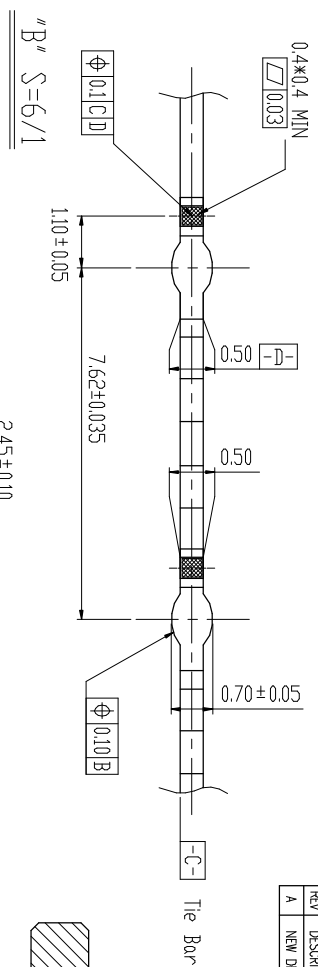

TABLE	UNPLATING/REEL	PLATING	PART NO.	DESCRIPTION			PIECE
1				UNDERPLATING	A Point	B Point	C Point

TABLE	UNPLATING/REEL	PLATING	PART NO.	UNDERPLATING	A Point	B Point	C Point	PIECE
2	C5860000A	C5862000A	C5862B20A	CU FLASH	AG 100μ"	AG 50μ"		20PIN

REVISION			
REV	DESCRIPTION	BY	DATE
A	NEW DRAWING	J.S.SHEU	01/13/09'



- NOTE:
1. MATERIAL: 0.50±0.025 THICK SPCC-SD
  2. BURR: 0.05 MAX. UNLESS OTHERWISE SPECIFIED.
  3. RADIUS: 0.30 MAX. ON ALL SHARP CORNERS UNLESS OTHERWISE SPECIFIED.
  4. CAN NOT BE DISCLDR AFTER BY 160° BAKING FOR 2 HOURS.

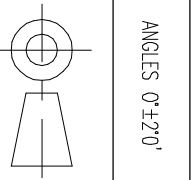

ANGLES 0°±20'		DR	DATE	MAT'L
MM	J.S.SHEU	01/13/09'	SEE NOTE 1	
0.0±0.13	CHK	J.S.SHEU	01/13/09'	FINISH
0.00±0.05	ENGR			SEE PART NO. TABLE
0.000±0.03	APPD			DWG. NO. M0344

CHALIN PRECISION INDUSTRIAL CO., LTD.			
DWG TYPE	TITLE	SCALE	SIZE
C	2004M4-13P	1:1	A4
PART NO.	REV	SHT 1 OF 2	
E03044-C58XXXXXA	A		