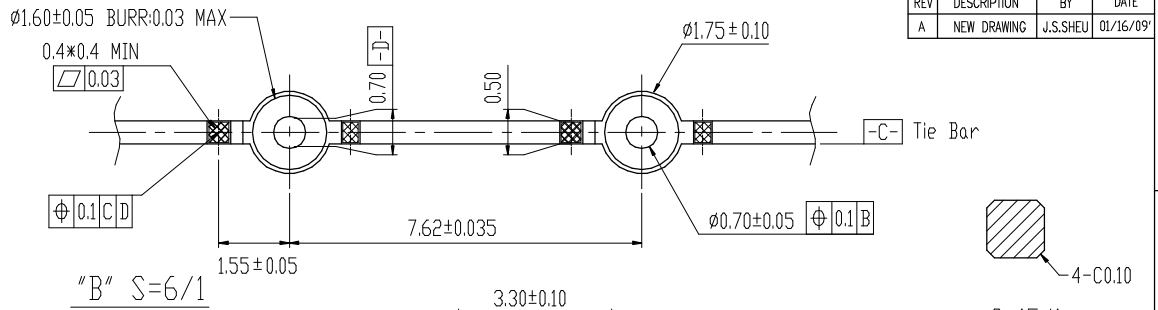

TABLE	UNPLATING REEL	PLATING	PART NO.	DESCRIPTION				
				UNDERPLATING	A Point	B Point	C Point	PIECE
1	B180000A	B186000A	B1860020A	CU FLASH	AG 80u"	AG FLASH	AG 80u"	20PIN

REVISION			
REV	DESCRIPTION	BY	DATE
A	NEW DRAWING	J.S.SHEU	01/16/09'

TABLE	UNPLATING REEL	PLATING	PART NO.	DESCRIPTION				
				UNDERPLATING	A Point	B Point	C Point	PIECE
2	B180000A	B1861000A	B1861020A	CU FLASH	AG 80u"	AG 50u"		20PIN



$S=15/1$
SECTION "A-A"

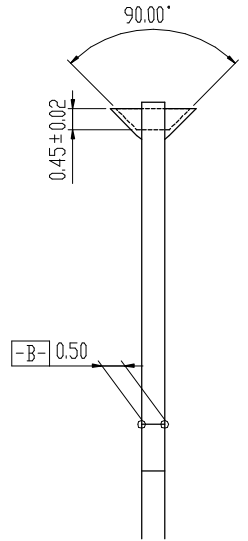
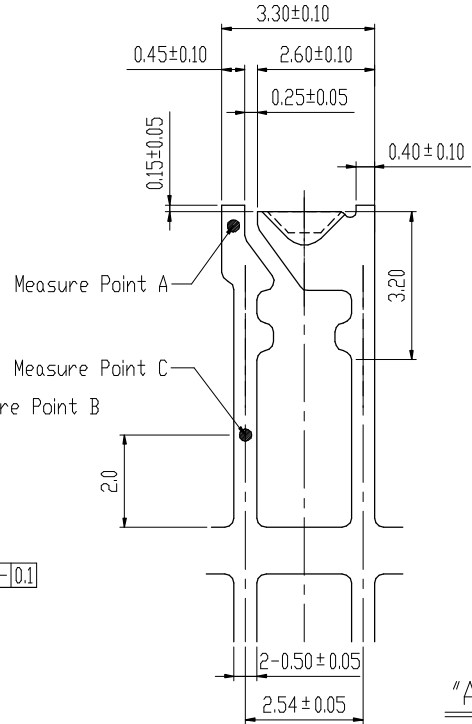
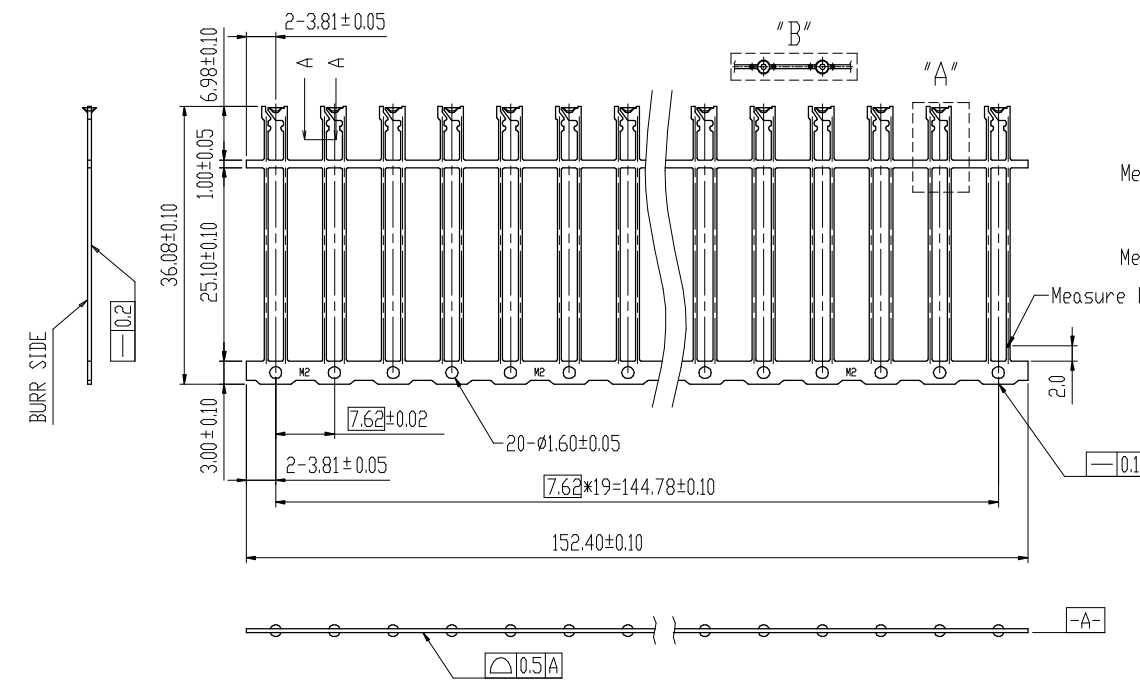

NOTE:
 1. MATERIAL: 0.50±0.025 THICK SPCC-SD.
 2. BURR: 0.05 MAX. UNLESS OTHERWISE SPECIFIED.
 3. RADIUS: 0.30 MAX. ON ALL SHARP CORNERS UNLESS OTHERWISE SPECIFIED.
 4. CAN NOT BE DISCOLOR AFTER BY 160° BAKING FOR 2 HOURS.

ANGLES 0°±20'	MM	DR	DATE	MAT'L
		J.S.SHEU	01/16/09'	SEE NOTE 1
	0.0±0.13	CHK	J.S.SHEU	01/16/09'
	0.00±0.05	ENGR		FINISH SEE PART NO. TABLE
	0.000±0.03	APPD		DWG.NO. M0344

CHIALIN PRECISION INDUSTRIAL CO.,LTD.			
DWG TYPE	TITLE	REV	
C	2003M2	A	
SCALE	SIZE	PART NO.	SHT 1 OF 2
1:1	A4	E03044-B18XXXXXA	